

**Model** : ATZ LK1708SL\_LK1716SL\_LK1908SL\_LK1916SL

**Description** : 17"/19" Combo LCD KVM Console Drawers w/extra Local Console  
- Optimize rack space. Maximize rack monitoring -



ATZ range of LCD console drawers provides a variety of features that simplify to access servers to making system monitoring, troubleshooting and software upgrades.

The self-locking rails when in the fully extended open position and the ultra-convenient auto lock release when the LCD panel is closed, make for simple and hassle free operation.

Available with 17" or 19" A-Grade LCD panels, combo Single, 8 or 16 port integrated KVM switch & with one extra local USB Console.

**Model** : ATZ LK1708SL\_LK1716SL\_LK1908SL\_LK1916SL

**Description** : 17"/19" Combo LCD KVM Console Drawers w/extra Local Console  
- Optimize rack space. Maximize rack monitoring -

## Features:

- Support combo interface, VGA-USB & VGA-PS/2.
- Single-Rail architecture in Heavy Duty Steel housing.
- Durable 104-key keyboard and touch pad.
- Quick and simple installation.
- Self-locking and auto release rails for ultra-convenience.
- Port selection via push buttons or On-Screen-Display (OSD).
- Dedicated daisy chain port to expand up to 240 servers.
- Extra local console for optional simultaneous access to KVM. (Replace IP slot)
- Access Control List (ACL) security function for up to 8 independent user accounts.

## Specifications:

Part No.	ATZ LK1708SL	ATZ LK1716SL	ATZ LK1908SL	ATZ LK1916SL
Direct no. of Computers	8	16	8	16
Maximum no. of Computers	232(Daisy Chain)	240(Daisy chain)	232(Daisy Chain)	240(Daisy chain)
LCD	Size	17"	19"	
	Backlight	LED		LED
	Resolution	1280*1024		1280*1024
	Max. color	16.7M		16.7M
	Luminance	250cd/m2		250cd/m2
	View Angel (H/V)	176 / 170		170 / 160
	Contrast Ratio	1000 : 1		1000 : 1
Port Selection	Push Button, OSD or Hotkey		Push Button, OSD or Hotkey	
USB Local Console	Yes, USB x2 for KB/ Mouse, VGA x1			
KB/Mouse Emulation	USB & PS2			
Rack Depth	500mm to 1100mm ( rack cabinet front rails to rear rails )			
Power	100-240V AC 50/60Hz via IEC Type power cord			
Environment	Operation temp: 0 to 50°C Storage temp: -20 to 60°C			

**Model** : ATZ LK1708SL\_LK1716SL\_LK1908SL\_LK1916SL

**Description** : 17"/19" Combo LCD KVM Console Drawers w/extra Local Console  
- Optimize rack space. Maximize rack monitoring -

	Humidity: 10% - 90%, non-condensing Shock: 10G acceleration ( 11ms duration) Vibration: 17 to 500Hz 1G PTP	
Physical Dimensions/ Net Weights	448x42x580mm (WxHxD) / 12.0KG	448x42x580mm (WxHxD) / 12.5KG
Packing Dimensions/Gross weights	715x140x780mm (WxHxD) / 18.0KG	715x140x780mm (WxHxD) / 18.5KG
<b>Accessory</b>		
1x 1.8m IEC Type Power Cord		
<b>Related Items</b>		
ATZ KCU-1.8	1.8meter 2-in-1 KVM Cable-USB&VGA	
ATZ KCU-3	3.0meter 2-in-1 KVM Cable-USB&VGA	
ATZ KCU-5	5.0meter 2-in-1 KVM Cable-USB&VGA	
ATZ KCP-1.8	1.8meter 3-in-1 KVM Cable-PS/2&VGA	
ATZ KCP-3	3.0meter 3-in-1 KVM Cable-PS/2&VGA	
ATZ KCP-5	5.0meter 3-in-1 KVM Cable-PS/2&VGA	

## Product Diagram:

### ATZ LK1708SL\_1908SL

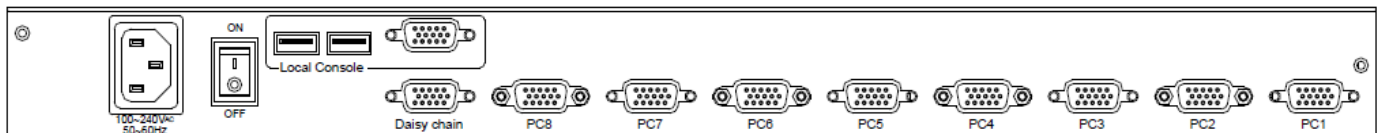

### ATZ LK1716SL\_1916SL

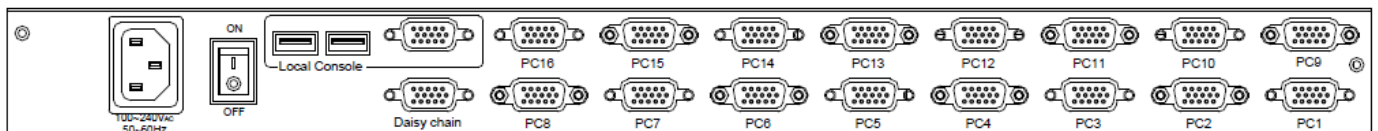

**Model** : ATZ LK1708SL\_LK1716SL\_LK1908SL\_LK1916SL

**Description** : 17"/19" Combo LCD KVM Console Drawers w/extra Local Console

- Optimize rack space. Maximize rack monitoring -

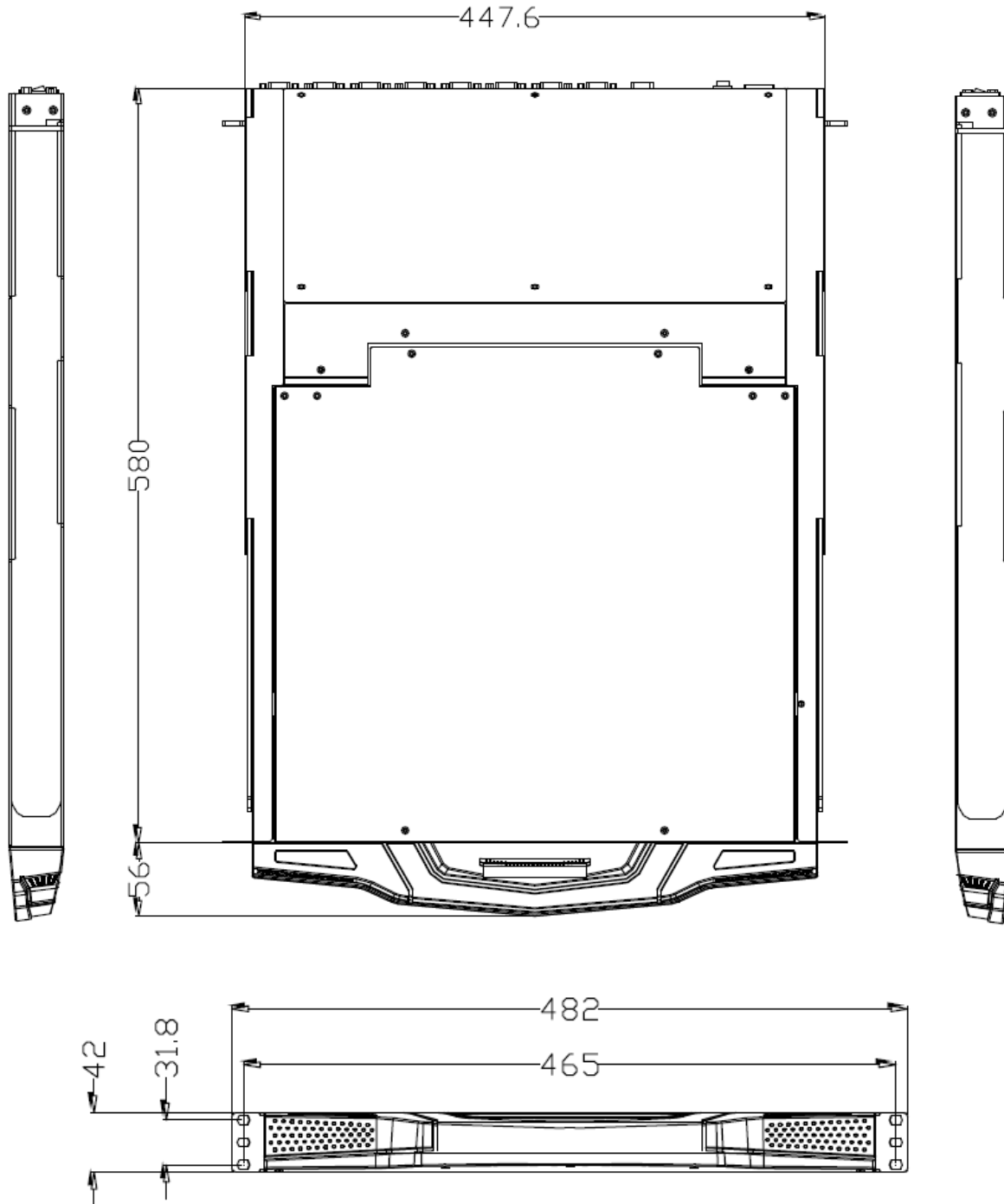

**Model** : ATZ LK1708SL\_LK1716SL\_LK1908SL\_LK1916SL

**Description** : 17"/19" Combo LCD KVM Console Drawers w/extra Local Console  
- Optimize rack space. Maximize rack monitoring -

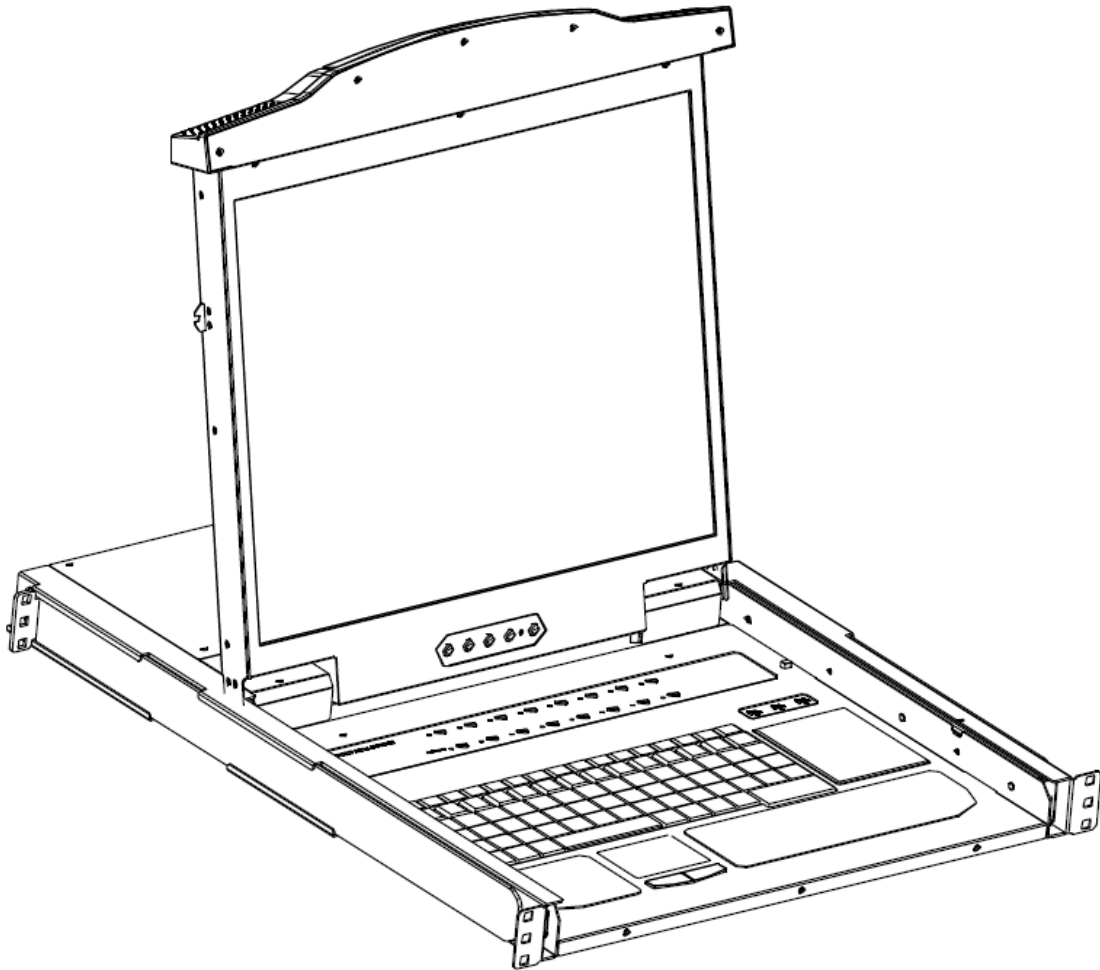

### **Warranty: 3 Years**

Warranty is effective from the date of original delivery.

This warranty shall be void if a serial number has been removed from the product.