

Model : ATZ LK1701D/LK1708D/LK1716D/LK1901D/LK1908D/LK1916D
Description : 17"/19" Combo LCD KVM Console Drawers (Dual rail)
- Optimize rack space. Maximize rack monitoring -



ATZ range of LCD console drawers provides a variety of features that simplify to access servers to making system monitoring, troubleshooting and software upgrades.

Flexible dual rail design, capable LCD screen and keyboard tray operated independently.

The self-locking rails when in the fully extended open position and the ultra-convenient auto lock release when the LCD panel is closed, make for simple and hassle free operation.

Available with 17" or 19" A-Grade LCD panels, combo DB15 single, 8 or 16 port integrated KVM switch & with an option remote IP console.

Model : ATZ LK1701D/LK1708D/LK1716D/LK1901D/LK1908D/LK1916D
Description : 17"/19" Combo LCD KVM Console Drawers (Dual rail)
- Optimize rack space. Maximize rack monitoring -

Optional Remote IP Access

- An expansion slot allows you to add an optional KVM over IP module to enable remote access to your servers.
- Gain BIOS level access to your servers for system maintenance, support or failure recovery via secure SSL authentication and encryption.

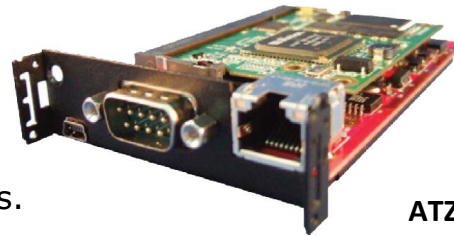

ATZ IP101

Features:

- Support combo interface, VGA-USB & VGA-PS/2.
- Dual slide rail capable LCD screen and keyboard tray independent Operate.
- Durable 104-key keyboard and touch pad.
- Quick and simple installation.
- Self-locking and auto release rails for ultra-convenience.
- Port selection via push buttons or On-Screen-Display (OSD).
- Dedicated daisy chain port to expand up to 240 servers.
- Access Control List (ACL) security function for up to 8 independent user accounts.

Model : ATZ LK1701D/LK1708D/LK1716D/LK1901D/LK1908D/LK1916D
Description : 17"/19" Combo LCD KVM Console Drawers (Dual rail)
 - Optimize rack space. Maximize rack monitoring -

Specifications:

Part No.	ATZ LK1701D	ATZ LK1708D	ATZ LK1716D	ATZ LK1901D	ATZ LK1908D	ATZ LK1916D
Direct no. of Computers	1	8	16	1	8	16
Maximum no. of Computers	1	232(Daisy Chain)	240(Daisy chain)	1	232(Daisy Chain)	240(Daisy chain)
LCD	Size	17"		19"		
	Backlight	LED		LED		
	Resolution	1280*1024		1280*1024		
	Max.color	16.7M		16.7M		
	Luminance	250cd/m2		250cd/m2		
	View Angel (H/V)	176 / 170		170 / 160		
	Contrast Ratio	1000 : 1		1000 : 1		
Port Selection	N/A	Push Button, OSD or Hotkey		N/A	Push Button, OSD or Hotkey	
Expansion Slot	N/A	Yes, option for Remote IP Access		N/A	Yes, option for Remote IP Access	
KB/Mouse Emulation	USB & PS2					
Rack Depth	522mm to 1100mm (rack cabinet front rails to rear rails)					
Power	100-240V AC 50/60Hz via IEC Type power cord					
Environment	Operation temp: 0 to 50°C Storage temp: -20 to 60°C Humidity: 10% - 90%, non-condensing Shock: 10G acceleration (11ms duration) Vibration: 17 to 500Hz 1G PTP					
Physical Dimension/N.W	449.8x44.4x685mm (WxHxD) / 13.0KG			449.8x44.4x685mm (WxHxD) / 13.5KG		
Packing Dimension/G.W	710x185x910mm (WxHxD) / 20.0KG			710x185x910mm (WxHxD) / 20.5KG		
Accessory						
1x 1.8meter IEC Type Power Cord 1x 1.8meter VGA& PS2 Cable 1x 1.8meter USB Type-A Cable (for ATZ LK1701_1901D)						

Model : ATZ LK1701D/LK1708D/LK1716D/LK1901D/LK1908D/LK1916D
Description : 17"/19" Combo LCD KVM Console Drawers (Dual rail)
 - Optimize rack space. Maximize rack monitoring -

Optional	
ATZ KCU-1.8	1.8meter 2-in-1 KVM Cable-USB&VGA
ATZ KCU-3	3.0meter 2-in-1 KVM Cable-USB&VGA
ATZ KCU-5	5.0meter 2-in-1 KVM Cable-USB&VGA
ATZ KCP-1.8	1.8meter 3-in-1 KVM Cable-PS/2&VGA
ATZ KCP-3	3.0meter 3-in-1 KVM Cable-PS/2&VGA
ATZ KCP-5	5.0meter 3-in-1 KVM Cable-PS/2&VGA
ATZ IP-101	KVM over IP module for Remote Bios Level Access

Product Diagram:

ATZ LK1701_1901D

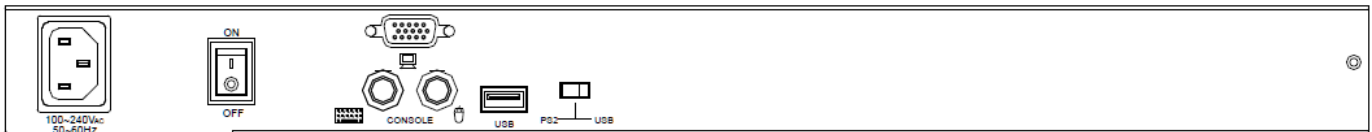

ATZ LK1708_1908D

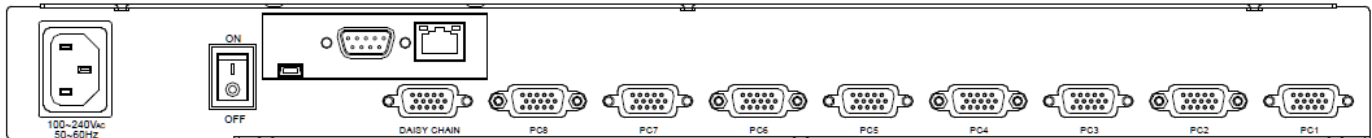

ATZ LK1716_1916D

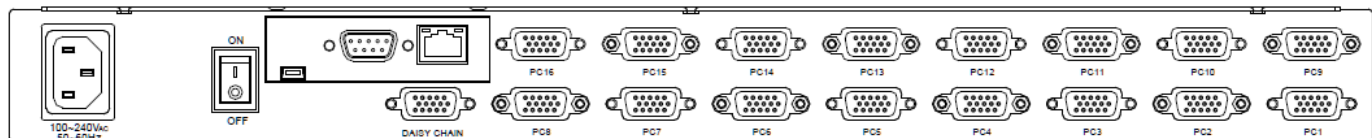

Model : ATZ LK1701D/LK1708D/LK1716D/LK1901D/LK1908D/LK1916D
Description : 17"/19" Combo LCD KVM Console Drawers (Dual rail)
- Optimize rack space. Maximize rack monitoring -

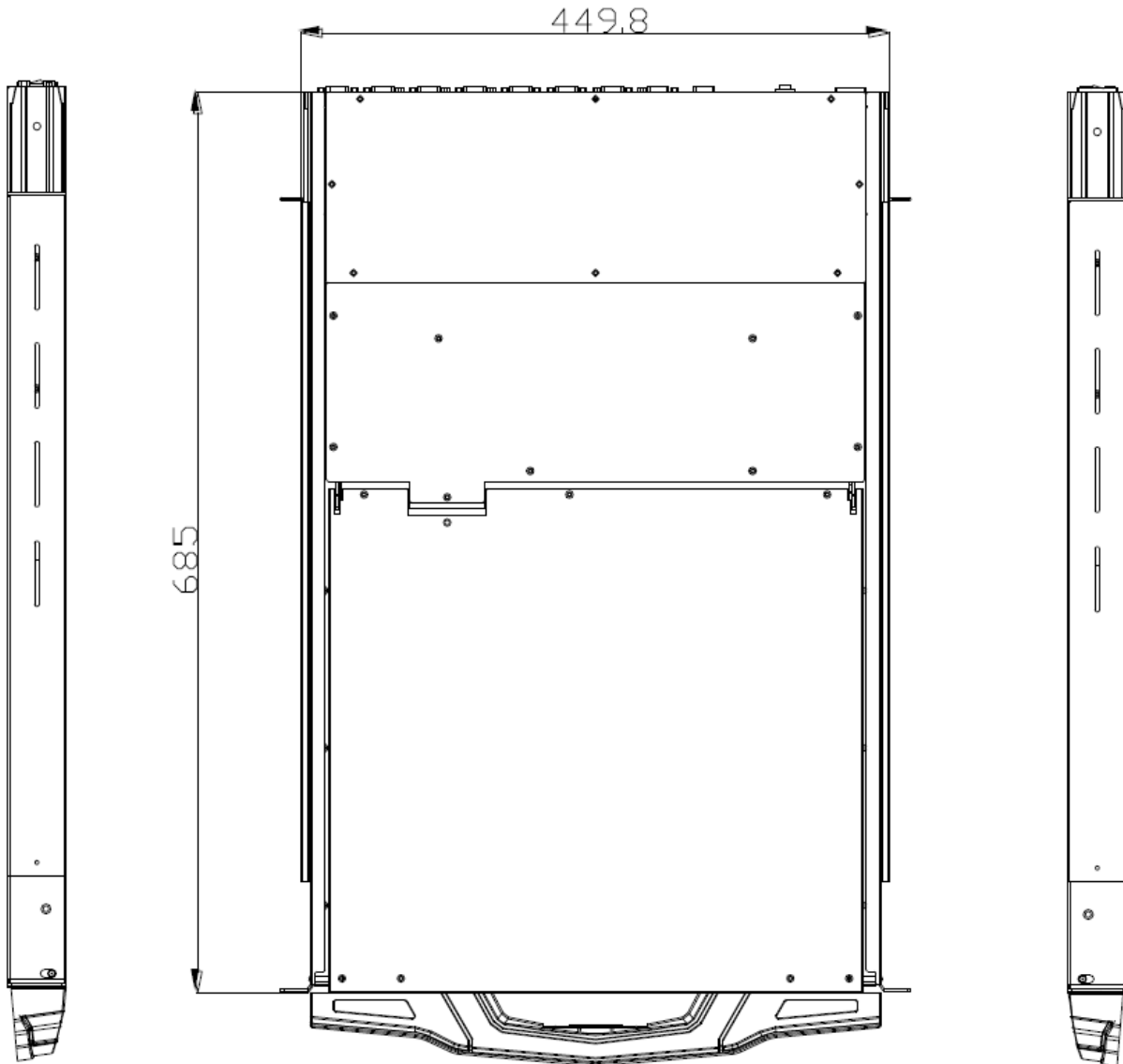

Model : ATZ LK1701D/LK1708D/LK1716D/LK1901D/LK1908D/LK1916D

Description : 17"/19" Combo LCD KVM Console Drawers (Dual rail)

- Optimize rack space. Maximize rack monitoring -

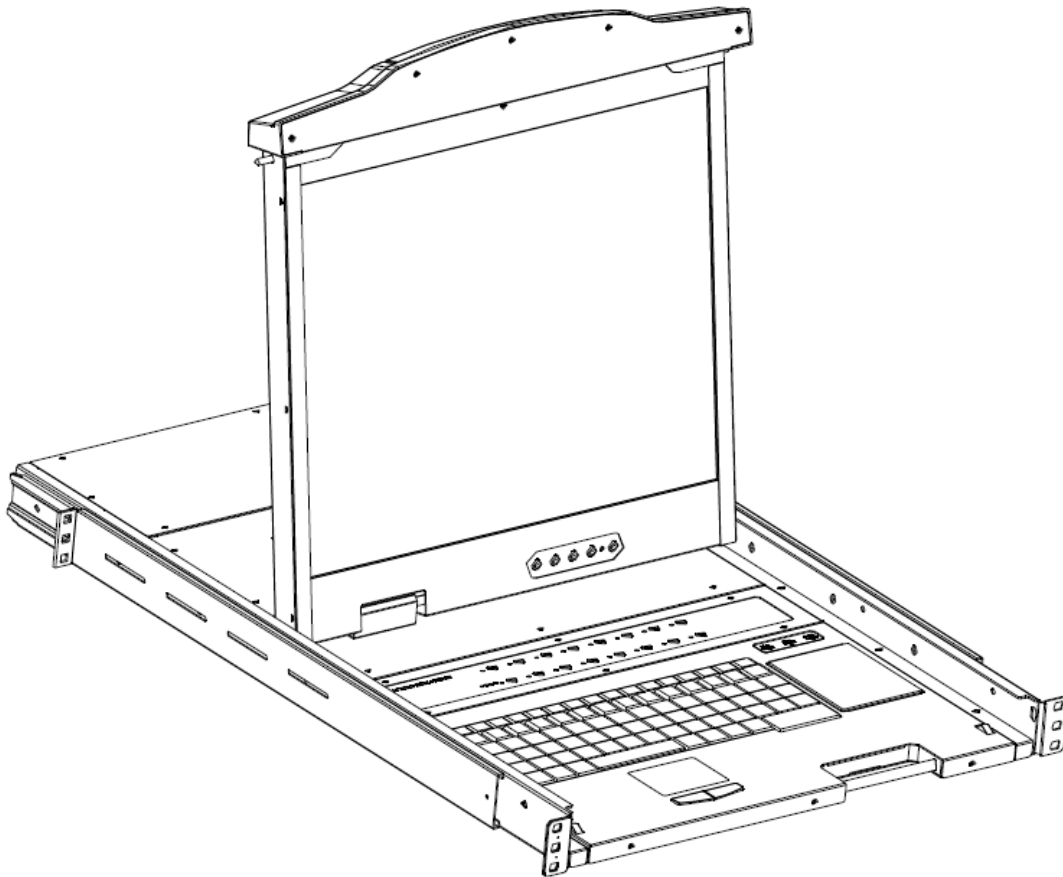
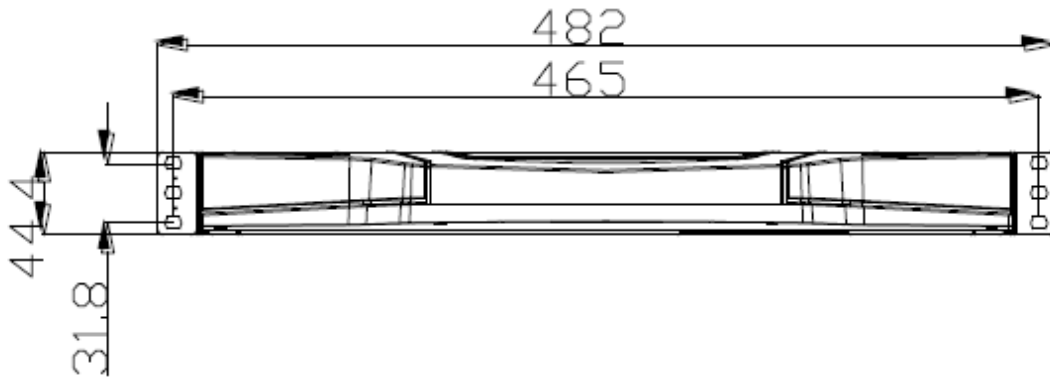

Model : ATZ LK1701D/LK1708D/LK1716D/LK1901D/LK1908D/LK1916D
Description : 17"/19" Combo LCD KVM Console Drawers (Dual rail)
- *Optimize rack space. Maximize rack monitoring* -

Warranty: 3 Years

Warranty is effective from the date of original delivery.

This warranty shall be void if a serial number has been removed from the product.