

**Model** : ATZ LK1701W-D2

**Description** : 17.3" FHD(1080p) Dual Monitor LCD Console Drawer + multi-input DVI/VGA/  
Audio/USB Hub.

- Optimize rack space. Maximize rack monitoring -



↑ (USB Port for device access)



**Model** : ATZ LK1701W-D2

**Description** : 17.3" FHD(1080p) Dual Monitor LCD Console Drawer + multi-input DVI/VGA/ Audio/USB Hub.

- Optimize rack space. Maximize rack monitoring -

## Features:

- 2U 17.3 inch widescreen Dual LCD Console Drawer
- Dual DVI & VGA Port
- 1920 x 1200 WUXGA Ultra high resolution
- Support FHD with 1080p resolution.
- Front 1xUSB, Rear 2xUSB 2.0 Type A, Sharing USB peripheral Device for computer (ex, flash disk, hard driver, KB/Mouse)
- 104-key keyboard with touch pad mouse.
- USB 2.0 Keyboard & Mouse
- Self-locking and auto release rails for ultra convenience.
- Build in 2x 2 watts speakers

## Optional:

- Composite Video input
- HDMI or Display Port input
- 3G / HD / SD –SDI Broadcast grade input
- 48V, 24V or 12V DC Power

## Specifications:

Part No.		ATZ LK1701W-D2
No. of ports		1
KVM Connectors		2 x DVI-D & 2x VGA / 1 x USB
LCD	Size	Dual 17.3 inch FULL HD display
	Backlight	LED
	Resolution	1920*1080 ( support resolution up to 1920*1200 )
	Max.color	262K
	Luminance	300 cd/m2
	View Angel (H/V)	140 / 120
	Contrast Ratio	650 : 1
Port Selection		N/A
USB HUB		Yes , Front x1 & Rear x 2 USB 2.0 Type A for USB Peripheral Device

**Model** : ATZ LK1701W-D2

**Description** : 17.3" FHD(1080p) Dual Monitor LCD Console Drawer + multi-input DVI/VGA/ Audio/USB Hub.

- Optimize rack space. Maximize rack monitoring -

Audio	1 x 3.5mm Audio jack
KB/Mouse Emulation	USB 2.0
Rack Depth ( rack cabinet front rails to rear rails )	600mm to 1100mm
Power	100-240V AC 50/60Hz via IEC Type power cord
Environment	Operation temp: 0 to 50°C Storage temp: -20 to 60°C Humidity: 10% - 90%, non-condensing Shock: 10G acceleration ( 11ms duration) Vibration: 17 to 500Hz 1G PTP
Physical Dimensions ( W x H x D ) / Net Weights (KG)	443x63x580mm / 14.5
Packing Dimensions ( W x H x D ) / Gross weights (KG)	735x590x215mm / 19.0
<b>Accessory</b>	
1x 1.8meter IEC Type Power Cord 2x 1.8meter DVI Cable 2x 1.8meter VGA Cable 1x 1.8meter USB Cable 1x 1.8meter Audio Cable	

**Model** : ATZ LK1701W-D2

**Description** : 17.3" FHD(1080p) Dual Monitor LCD Console Drawer + multi-input DVI/VGA/Audio/USB Hub.

- Optimize rack space. Maximize rack monitoring -

**Product Diagram:**

Rear of ATZ-LK1701W-D2

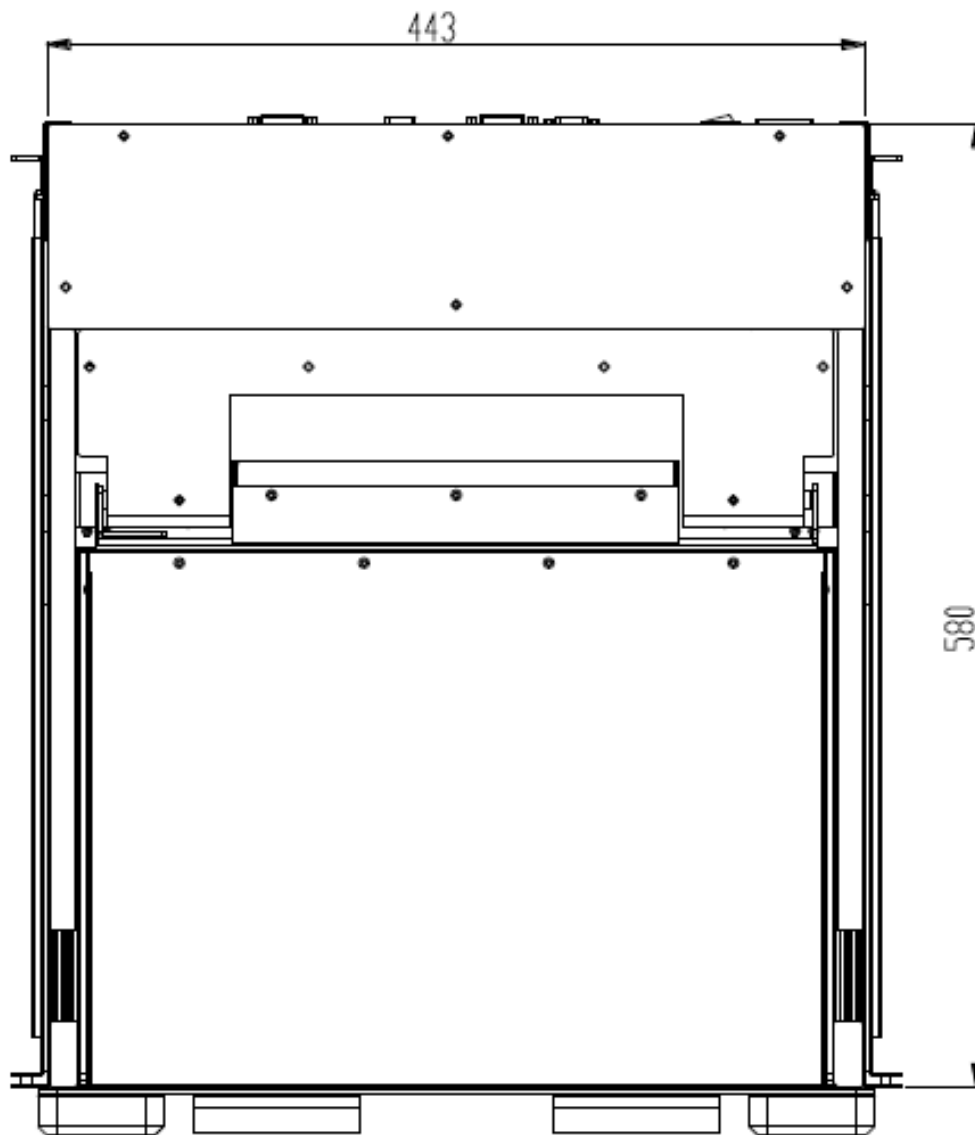
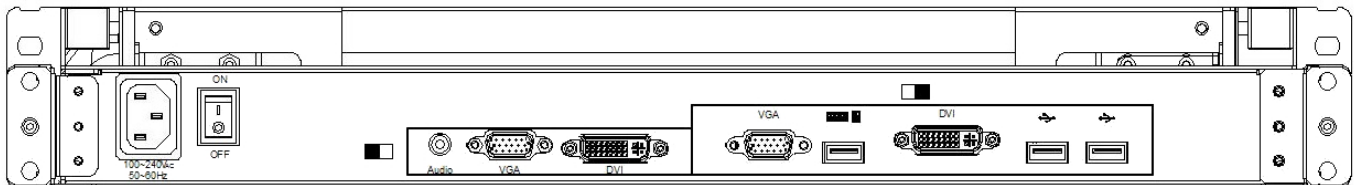

**Model** : ATZ LK1701W-D2

**Description** : 17.3" FHD(1080p) Dual Monitor LCD Console Drawer + multi-input DVI/VGA/  
Audio/USB Hub.

- Optimize rack space. Maximize rack monitoring -

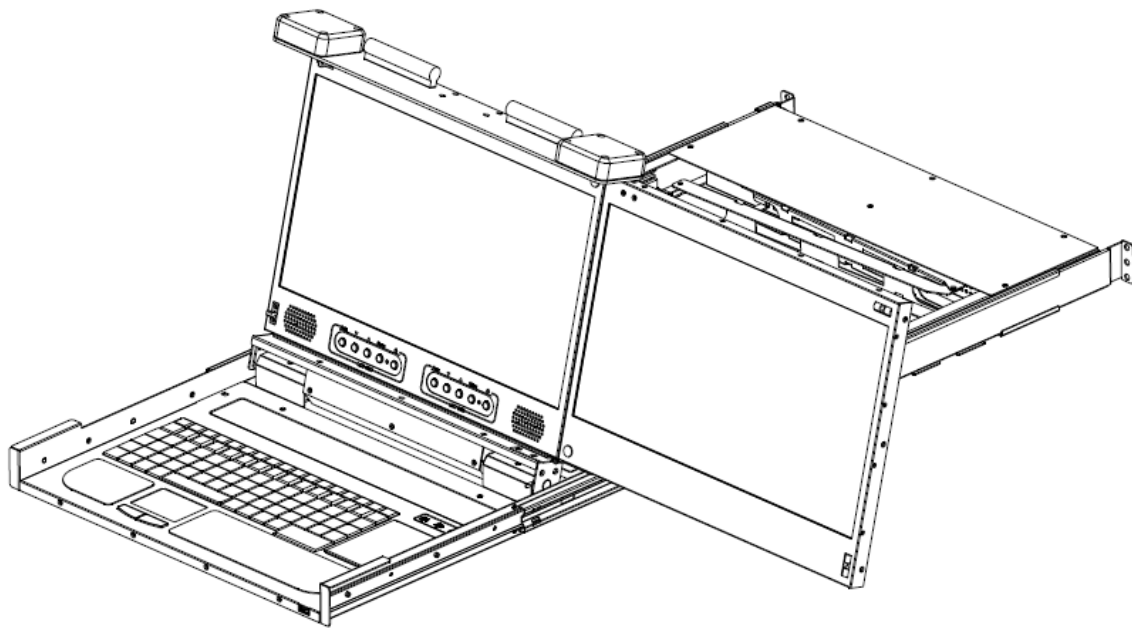
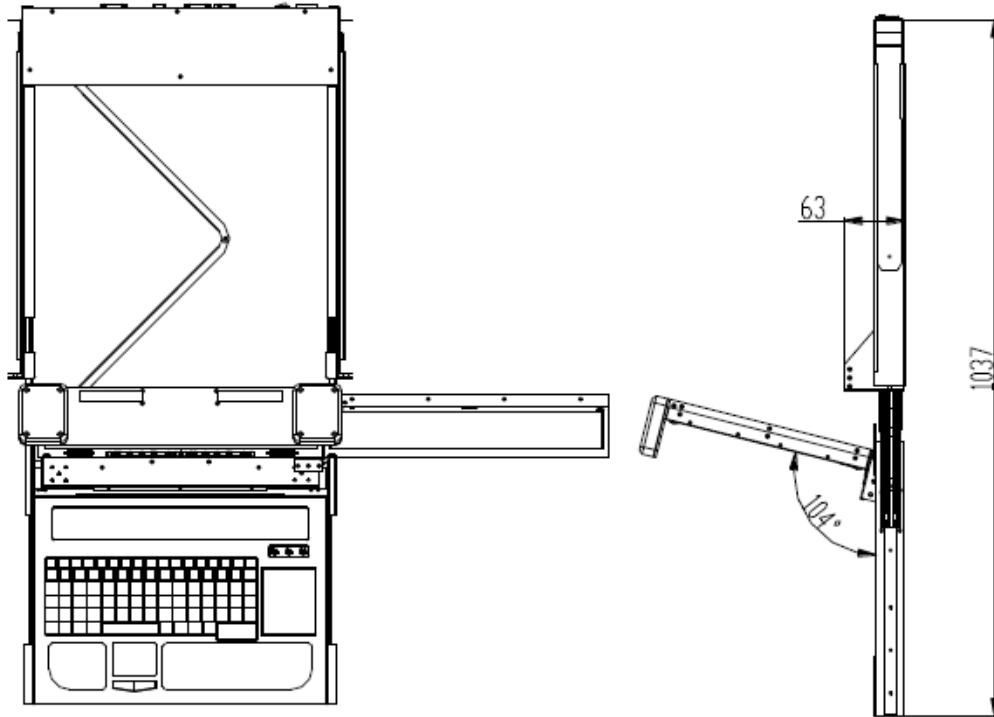

**Model** : ATZ LK1701W-D2

**Description** : 17.3" FHD(1080p) Dual Monitor LCD Console Drawer + multi-input DVI/VGA/  
Audio/USB Hub.

- *Optimize rack space. Maximize rack monitoring* -

---

### **Warranty: 3 Years**

Warranty is effective from the date of original delivery.

This warranty shall be void if a serial number has been removed from the product.