

Model : ATZ LKD19D2V

Description : 19" Dual vertical Screen LCD Console Drawer + multi input
DVI-D/VGA/Audio/USB Hub - Dual Rail
- Optimize rack space. Maximize rack monitoring -



Features:

- 2U dual vertical 19 inch LCD Console Drawer
- **LCD panel A-Grade**
- **Heavy Duty Steel housing**
- 2 gas struts to support LCD when open
- Dual DVI & VGA Port
- 1280 x 1024 resolution
- Dual rail design, capable the LCD screen and keyboard tray Operated independently.
- Front 1xUSB, Rear 2xUSB 2.0 Type A, Sharing USB peripheral

pg. 1

Notes: - All brand names and trademarks are properties of their respective holders and are referred to here for descriptive purpose only. Photo attached is for reference only, it may be slightly varied in items of colour, shape from the actual item delivered from time to time.

All specifications are subject to change without prior notice.

© Copyright

Model : ATZ LKD19D2V

Description : 19" Dual vertical Screen LCD Console Drawer + multi input
DVI-D/VGA/Audio/USB Hub - Dual Rail
- Optimize rack space. Maximize rack monitoring -

Device for computer (ex, flash disk, hard driver, KB/Mouse)

- 87-key keyboard with trackball mouse
- USB 2.0 Keyboard & Mouse
- Build in 2x 2 watts speakers

Optional:

- Composite Video input
- HDMI or Display Port input
- 3G / HD / SD –SDI Broadcast grade input
- 9~36V DC Power

Specifications:

Part No.		ATZ LKD19D2V
No. of ports		1
KVM Connectors		2 x DVI-D & 2x VGA / 1 x USB for KB & Mouse / 1x Audio
LCD	Size	Dual 19 inch
	Backlight	LED
	Resolution	1280*1024
	Max.color	16.7M
	Luminance	350 cd/m2
	View Angel (H/V)	170 / 170
	Contrast Ratio	1000 : 1
Port Selection		N/A
USB HUB		Yes , Front x1 & Rear x 2 USB 2.0 Type A for USB Peripheral Device
Audio		1 x 3.5mm Audio jack
KB/Mouse Emulation		USB 2.0
Rack Depth (rack cabinet front rails to rear rails)		610mm to 940mm
Power		100-240V AC 50/60Hz via IEC Type power cord
Environment		Operation temp: 0 to 50°C Storage temp: -20 to 60°C

pg. 2

Notes: - All brand names and trademarks are properties of their respective holders and are referred to here for descriptive purpose only. Photo attached is for reference only, it may be slightly varied in items of colour, shape from the actual item delivered from time to time.

All specifications are subject to change without prior notice.

© Copyright

Model : ATZ LKD19D2V

Description : 19" Dual vertical Screen LCD Console Drawer + multi input
DVI-D/VGA/Audio/USB Hub - Dual Rail
- Optimize rack space. Maximize rack monitoring -

	Humidity: 10% - 90%, non-condensing Shock: 10G acceleration (11ms duration) Vibration: 17 to 500Hz 1G PTP
Physical Dimensions (W x H x D) / Net Weights (KGs)	443x87x609mm / 21.0
Packing Dimensions (W x H x D) / Gross weights (KGs)	870x710x340mm / 29.0
Accessory	
1x 1.8meter IEC Type Power Cord 2x 1.8meter DVI Cable/ 2x 1.8meter VGA Cable 1x 1.8meter USB Cable 1x 1.8meter Audio Cable	

Product Diagram:

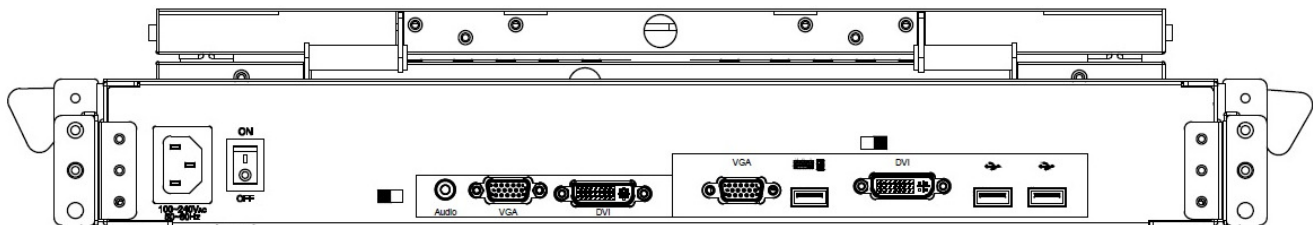

Rear view of ATZ LKD19D2V

Model : ATZ LKD19D2V

Description : 19" Dual vertical Screen LCD Console Drawer + multi input DVI-D/VGA/Audio/USB Hub - Dual Rail
 - Optimize rack space. Maximize rack monitoring -

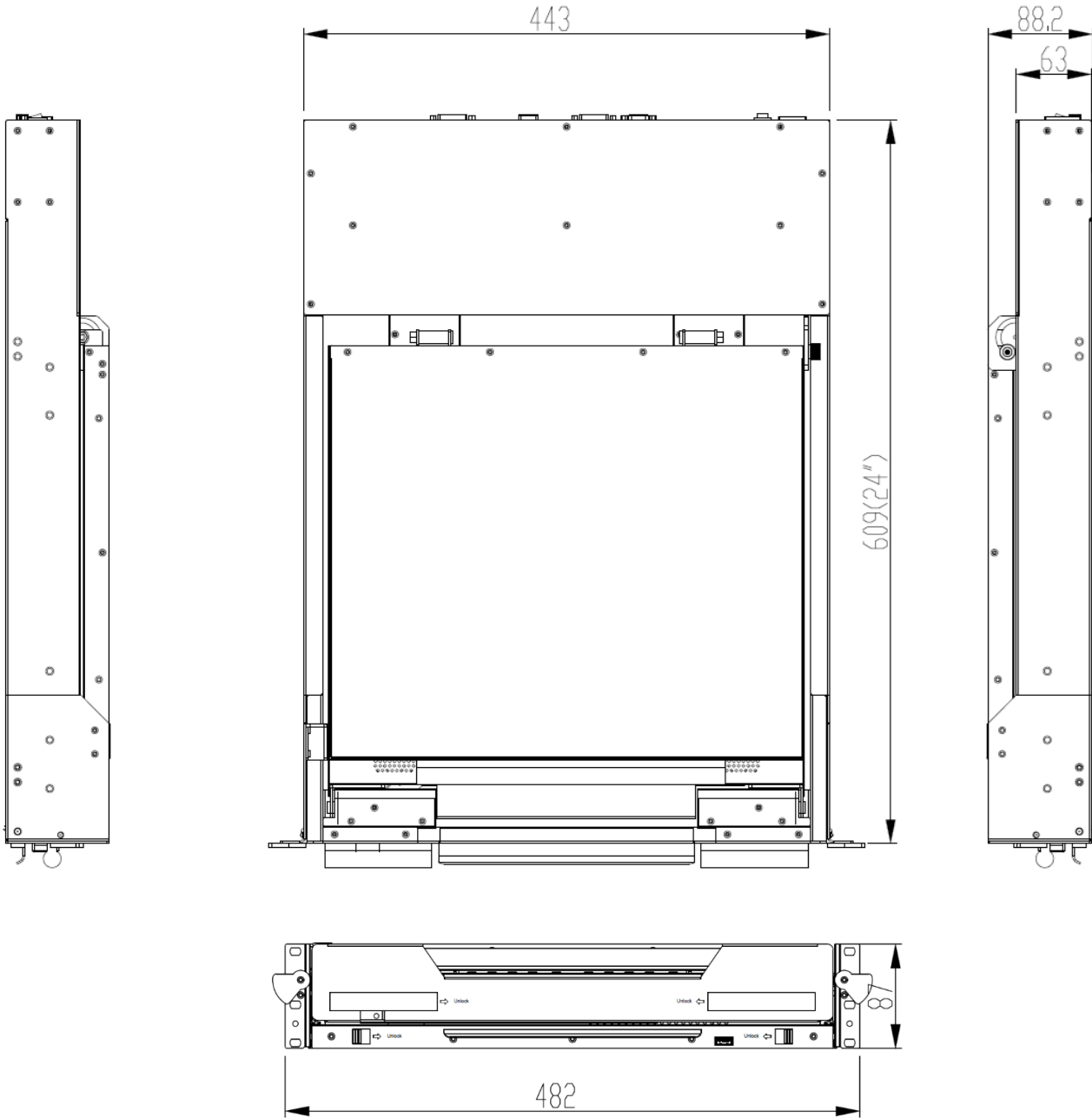

Model : ATZ LKD19D2V

Description : 19" Dual vertical Screen LCD Console Drawer + multi input
DVI-D/VGA/Audio/USB Hub - Dual Rail
- Optimize rack space. Maximize rack monitoring -

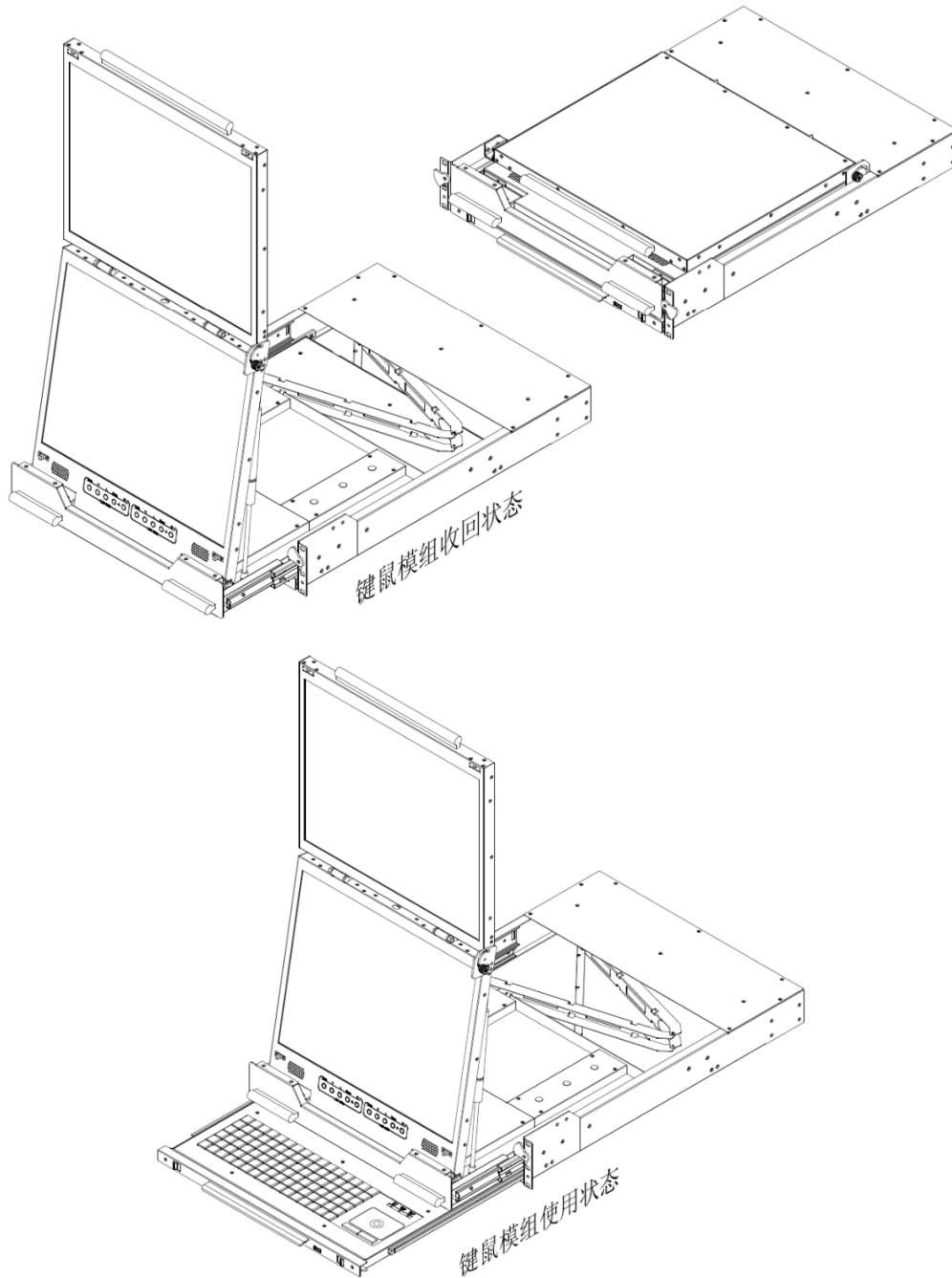

Model : ATZ LKD19D2V

Description : 19" Dual vertical Screen LCD Console Drawer + multi input DVI-D/VGA/Audio/USB Hub - Dual Rail
 - Optimize rack space. Maximize rack monitoring -

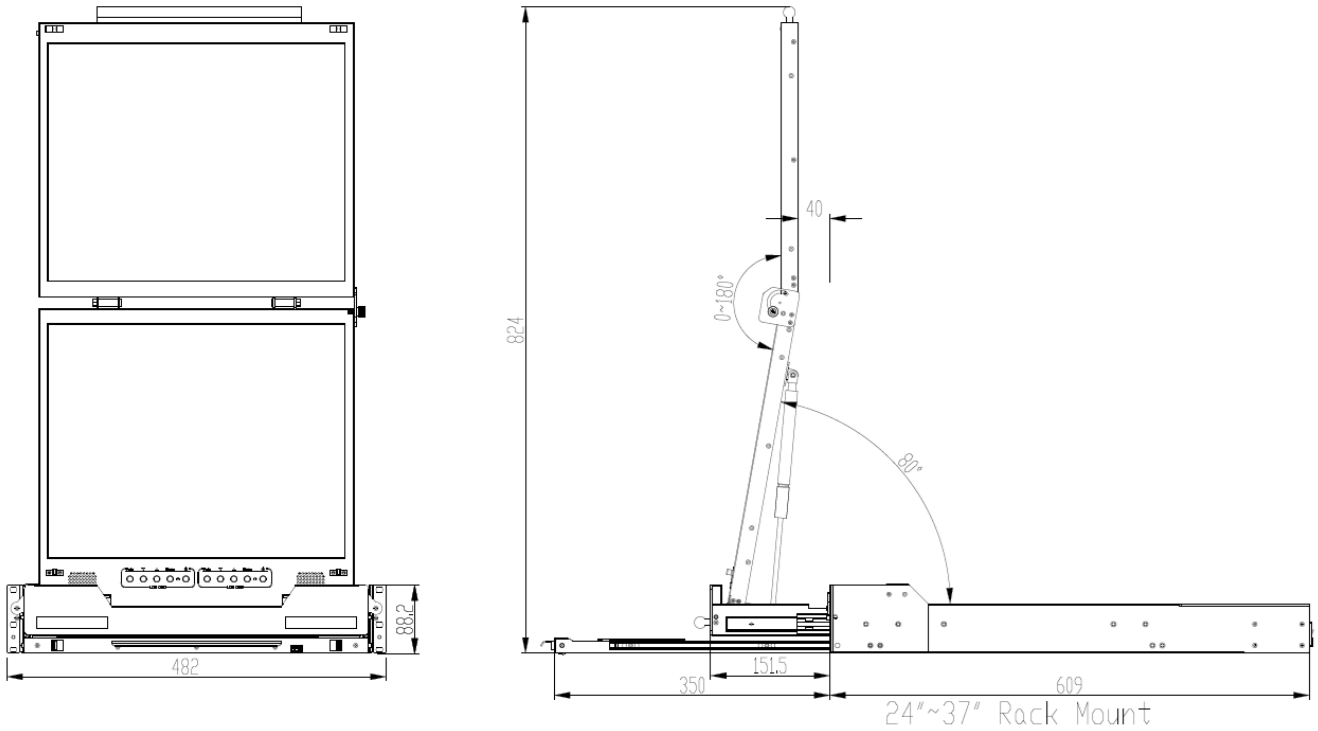

Warranty: 3 Years/ 2 Years-LED Screen

Warranty is effective from the date of original delivery.

This warranty shall be void if a serial number has been removed from the product.